

## Series Spec Sheet

# SLBIS

## DUST-TIGHT STEEL BATTERY UNIT

### FEATURES AND SPECIFICATIONS

#### • Circuitry

- 120/347 VAC or 277 VAC, 60 Hz Input
- High efficiency, rapid recovery, precision control charging system
- 30 minutes emergency power duration standard
- Dust-tight, momentary push button test switch
- Diagnostic/pilot LEDs for AC ON and CHARGE
- Brownout and short circuit protection
- Temperature compensated
- Large magnum terminal screw type connectors for remote load connection
- Complete battery recharge in 24 hours
- Maintenance free, sealed lead acid battery
- Optional automatic-testing, self-diagnostic charger board

#### • Mechanical

- 20 Gauge steel construction
- NEMA12 / EEMAC12 rated design
- Four integral mounting holes (one per corner)
- 120 VAC line cord with dust-tight strain relief supplied standard
- Industrial grey powder coat finish standard, other finishes optional
- Lamp heads include weatherproof die cast metal MR16 and high output industrial
- Top head mounting is standard, side mount is optional

#### • Approvals

- CSA Certified to C22.2 #141-15

#### • Compliance

- Meets requirements of ICES-005

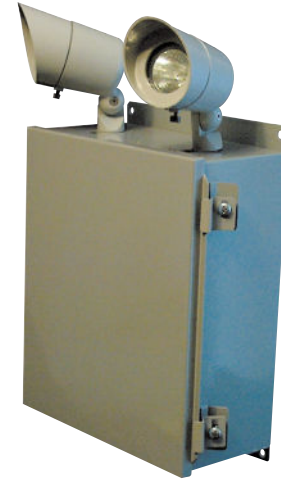

### OVERVIEW

Light source	LED, Quartz halogen
Input voltage (VAC)	120/347, 277
Output voltage (VDC)	6, 12, 24
Output power (W)	36 - 360



ICES  
005



For complete warranty details, please see our terms and conditions on our website.

## TYPICAL SPECIFICATION



### TYPICAL SPECIFICATION

Supply and install Stanpro SLBIS. The unit shall be rated 120 V, 277 V or 347 V, 60 Hz constructed of durable fully gasketed, all steel dust tight housing and be NEMA12 and EEMAC12, CSA listed to C22.2 141-15 and be ICES 005 compliant. The unit shall have an output of: \_\_\_ V and \_\_\_ W and come complete with (2) x \_\_\_ W LED heads producing (\_\_\_) lumens each. The charge voltage factory set to  $\pm 1\%$  tolerance. High efficiency, rapid recovery, precision control charging system shall be employed to promote long battery life and reduce the potential for grid corrosion. The charger shall provide a continuous high charge to recharge the battery, when the battery is at full capacity, the charger will shut-off. Periodically the charger shall provide a pulse of energy to keep the battery at full voltage. The pulse charger shall be precisely regulated and shall charge the battery in relation to its temperature, state or charge and input voltage fluctuations. The charger shall be current limited, temperature compensated, short-circuit proof and reverse polarity protected. The unit shall be furnished with an electronic lockout circuit, which will connect the battery when the AC circuit is activated, and an electronic brownout circuit, which will activate the emergency lights when utility power dips below 75% of nominal voltage. A low voltage battery protection circuit shall be provided and will disconnect the load when the battery reaches the end of discharge. The Stanpro battery shall come complete with an auto diagnostic micro-controller board and shall supply the rated load for a minimum of a 1/2 hour to 87.5% of the rated battery voltage. The Stanpro battery unit shall come complete with the Auto Test function. The automated testing performed by the Stanpro auto test system has been designed to comply with all of the requirements of the National Fire Code. Every month a 5 minute discharge and diagnostic test checks the operational status of the unit. Every 12 months, this test is extended to the full 30 minute, code required duration. This ensures that the battery charger is recharging the battery in accordance with code requirements. The unit shall be Stanpro model: SLBIS\_\_\_\_\_

Data is based upon tests performed in a controlled environment. Actual performance can vary depending on operating conditions. All products are subject to change or may be discontinued any time without notice.

**ORDERING GUIDE**

<b>SLBIS</b>					<b>GY</b>		
Series	Volts (V)	Watts	Head / Lamp	Lamp	Color	Input volts (V)	Options
SLBIS	06 - 6 12 - 12 24 - 24	See model rating below	00 - No Heads 1D - One MR16 Weather-Proof 2D - Two MR16 Weather-Proof 1I - One Industrial 2I - Two Industrial	See lamp selection	GY - Grey (standard)	Blank - 120/347 E - 277	A, ACTB, AT, AUD <sup>1</sup> , AUE, DCTB, FD6, IRT, LD, OBM, RFS, TD, TLP

<sup>1</sup> Only available with AT.

**MODEL RATINGS**

Model	Volts (V)	Wattage capacities (W)				Size	
		30 min.	60 min.	90 min.	120 min.		
SLBIS06036	6	36	18	12	9	1 <sup>1</sup>	
SLBIS06050		50	25	16	12	1 <sup>1</sup>	
SLBIS06072		72	36	24	18	1 <sup>1</sup>	
SLBIS06100		100	50	33	25	1 <sup>1</sup>	
SLBIS06160		160	80	53	40	2	
SLBIS06180		180	90	60	45	2	
SLBIS12036	12	36	18	12	9	1 <sup>1</sup>	
SLBIS12050		50	25	16	12	1 <sup>1</sup>	
SLBIS12072		72	36	24	18	1 <sup>1</sup>	
SLBIS12100		100	50	33	25	1 <sup>1</sup>	
SLBIS12160		160	80	53	40	2	
SLBIS12200		200	100	66	50	2	
SLBIS12250		250	125	83	62	2	
SLBIS12360		360	180	120	90	2	
SLBIS24144		24	144	72	48	36	2
SLBIS24200			200	100	66	50	2
SLBIS24320	320		160	106	80	2	

<sup>1</sup>Some options might require a cabinet 2.

**LAMP SELECTION**

MR16 • Small head c/w MR16 or LED lamp	6 V	12 V	24 V
LED	4LR, 5LA	4LR, 5LA, 6LA, 7LA	4LR, 5LA, 6LA, 7LA
Quartz halogen	10Q	20Q, 35Q	12Q, 20Q, 50Q

Industrial High output	6 V	12 V	24 V
LED		5LJ, 9LJ, 14LJ	5LJ, 9LJ, 14LJ

**Note:** Due to cabinet/space limitations, not all options are available for all models in any given combination. Please consult with your factory representative regarding specific options and exact cabinet dimension information.

**EMERGENCY LIGHTING OPTIONS**

Option	Description
A	Ammeter
ACTB	AC Terminal Block
AT	Automatic test self-diagnostic
AUD	Audible alarm
AUE	Audible emergency
DCTB	DC Terminal Block
FD6	6 Circuit Fused Internal Distribution
IRT	Infrared Remote Test
LD	Lamp disconnect (internal)
OBM	Octagon Box Mount (line cord delete)
RFS	Radio frequency suppression
TD	Time delay
TLP	Twist Lock Plug

**LUMEN TABLE**

Watts	Lumens
4W LR	388
5WLJ	590
5W LA	435
6W LA	507
7W LA	652

Data is based upon tests performed in a controlled environment. Actual performance can vary depending on operating conditions. All products are subject to change or may be discontinued any time without notice.

**WIREGUARD<sup>1</sup>**

	Part number	Dimensions (in)
Cabinet 1 <sup>2</sup>	WDG600-V2	23 x 20 x 12
Cabinet 2 <sup>2</sup>		

<sup>1</sup> Please contact your customer service representative for more information.  
<sup>2</sup> For I heads, please contact your customer service representative for more information.

**DIMENSIONS**

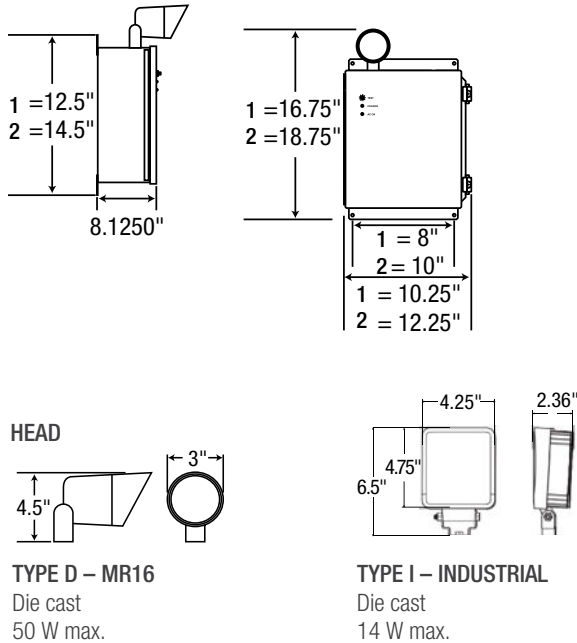

**SPACING GUIDE**

Mounting height	Spacing center to center (ft)							I HEAD		
	3LJ	4LJ	5LJ	4LR	5LA	6LA	7LA	5 W	9 W	14 W
8 ft	78	83	118	76	81	94	108	113	165	199
10 ft	75	76	118	79	79	93	106	110	160	194
15 ft	66	68	104	66	62	82	96	99	147	178
20 ft	53	53	91	53	49	73	87	86	133	164

Data is based upon tests performed in a controlled environment. Actual performance can vary depending on operating conditions. All products are subject to change or may be discontinued any time without notice.