

Series spec sheet

SLC-MIV

PURE-SINE WAVE IPS MINI-INVERTER

The SLC-MIV pure sine wave inverter represents a unique approach to power failure lighting applications. Pure sine wave inverters are ideal, as opposed to square or modified wave inverters, which will break down electronic ballasts and LED drivers prematurely. Stanpro's pure sine wave inverter was designed to run up to 1 440 W for 30 minutes on normally ON and OFF LED, CFL, fluorescent or incandescent lighting fixtures.

FEATURES AND SPECIFICATIONS

• Construction

Normally OFF

By combining a battery unit and off-line inverter with superior 120 V or 347 V lighting performance for all types of lighting fixtures, the SLC-MIV provides exceptional power failure lighting. The typically configured battery unit is paired with an off-line, internally mounted, pure-sine wave inverter. When AC power is present there is no output and the connected fixtures are off, when the AC power fails, the unit outputs 120 V AC or 347 V AC to the connected lighting fixtures at 100% brightness.

Normally ON

This feature is easily activated by connecting a normally-ON lighting circuit to the unit. When AC power is present there is output and the connected lighting fixtures are on. When the AC power fails, the output is then transferring instantaneously to the power failure mode of the inverter and the connected lighting fixtures stay on.

• Electrical

- 120 V AC input / 120 V AC output or 347 V AC input / 347 V AC output
- Transfer time of 400ms
- Momentary push button test switch
- Diagnostic/pilot LEDs for AC ON and CHARGE
- Fully automatic, current limited charger
- Line latched, low voltage protection
- Brownout and short circuit protection

- Terminal block connectors for output load
- Dimming override control is standard
- Auto transfer switch for normally-on lighting circuit
- Maintenance free, sealed lead acid battery(s)

Overload protectors:

- **1 000 W:** Fuse allowing max load of 175 A and board protector with protection up to 1 100 W
- **1 440 W:** Fuse allowing max load of 175 A and board protector with protection up to 1 500 W
- **Optional automatic-testing, self-diagnostic charger:**
 - Continuously monitors the unit's status
 - Automatically performs battery load testing and auto-cycling at preset intervals
 - Indicates malfunctions or auto-test failures
 - May accept load to 80% capacity when load feature power factor of 0.9 or more

• Mechanical

- 18 Gauge steel construction (cabinet A and B), 16 Gauge steel construction (cabinet C)
- Universal spider knockout pattern and keyhole mounting slots stamped into back of cabinet
- Multiple conduit entry knockouts
- Air intake and exhaust fan placed on the sides for 1 000 W and more
- White powder coat finish standard
- Separate battery compartment

• Approvals

- CSA certified to C22.2 #141-15



OVERVIEW

| | |
|------------|---------------------------------------|
| Electrical | Normally ON and OFF |
| | 120 V AC or 347 V AC input and output |
| Mechanical | Separate battery compartment |
| | Steel construction |



TYPICAL SPECIFICATION



TYPICAL SPECIFICATION

1. Supply and install The Stanpro SLC-MIV mini-inverter designed to provide power output based on the input voltage, either 120 V AC or 347 V AC. The SLC-MIV features a transfer time of 400ms, a momentary push-button test switch, diagnostic LEDs for AC ON and CHARGE indication, a fully automatic current-limited charger, line-latched low voltage protection, and brownout and short circuit protection. The device includes terminal block connectors for output load, standard dimming override control, an auto transfer switch for normally-on lighting circuits, and maintenance-free sealed lead-acid battery(s). The SLC-MIV also incorporates overload protectors and is constructed using steel cabinets with knockout patterns, keyhole mounting slots, multiple conduit entry knockouts, and air intake/exhaust fans for models with 1,000 W and above. The device is finished with a white powder coat and includes a separate battery compartment the SLC-MIV shall be CSA certified to C22.2 #141-15.

2. Electrical Specifications:

- Input Voltage: 120 V AC or 347 V AC
- Output Voltage: 120 V AC or 347 V AC
- Transfer Time: 400ms
- Push-Button Test Switch: Momentary type
- Diagnostic LEDs: AC ON and CHARGE indication
- Charger Type: Fully automatic, current-limited
- Protection Features: Line-latched low voltage protection, brownout protection, short circuit protection
- Output Load Connectors: Terminal block connectors
- Dimming Override Control: Standard feature
- Auto Transfer Switch: Included for normally-on lighting circuits
- Battery Type: Maintenance-free, sealed lead-acid
- Overload Protection:
 - 1,000 W Model: Fuse allowing a maximum load of 175 A and board protector with protection up to 1,100 W
 - 1,440 W Model: Fuse allowing a maximum load of 175 A and board protector with protection up to 1,500 W

3. Mechanical Specifications:

- Cabinet Construction:
 - Cabinet A and B: 18 Gauge steel construction
 - Cabinet C: 16 Gauge steel construction
- Mounting Options: Universal spider knockout pattern and keyhole mounting slots stamped into the back of the cabinet
- Conduit Entry Knockouts: Multiple knockouts provided
- Air Intake/Exhaust: Side-mounted fans for models with 1,000 W and above
- Finish: Standard white powder coat finish
- Battery Compartment: Separate compartment for battery storage

4. Approvals:

- CSA Certification: Certified to C22.2 #141-15 standards

The Stanpro SLC-MIV shall be model number

Data is based upon tests performed in a controlled environment. Actual performance can vary depending on operating conditions. All products are subject to change or may be discontinued any time without notice.

ORDERING GUIDE

| SLC-MIV | — | — | — | WH | / | — |
|---------|----------------------|--|------------|--|---|---|
| Series | Input Voltage (V AC) | Capacity (W) | Color | Option | | |
| SLC-MIV | A - 120 H - 347 | 320 - 320 ^{1,3} 500 - 500 ^{1,3} 1000 - 1 000 ^{1,2} 1440 - 1 440 ^{1,2} | WH - White | AT - Auto-test self-diagnostic (non audible) | | |

¹ May accept load to 80% capacity when load feature power factor of 0.9 or more
² May accept the surge peak lighting load of 3000W for 0.5 seconds for 1000W and above
³ May accept the surge peak lighting load of 1200W for 0.5 seconds for 320W and 500W

ACCESSORY (order separately)

See dimension next page.

| Part number | Type |
|-------------|------------------------------------|
| SHELF001 | Rigid 14 gauge free standing shelf |

MINI INVERTER MODEL RATINGS

| Model | Volts (V) | 30 min. | 60 min. | 90 min. | 120 min. | 180 min. |
|---------------|-----------|---------|---------|---------|----------|----------|
| SLC-MIV12320 | 12 | 320 | 180 | 125 | 110 | 75 |
| SLC-MIV12500 | 12 | 500 | 280 | 195 | 175 | 125 |
| SLC-MIV121000 | 12 | 1000 | 565 | 395 | 350 | 250 |
| SLC-MIV121440 | 12 | 1440 | 850 | 595 | 525 | 375 |

WEIGHT

120 V

| Watts (W) | Cabinet | without battery(s) (lbs) | with battery(s) (lbs) |
|-----------|-----------|--------------------------|-----------------------|
| 320 | Cabinet B | 29.2 | 53 |
| 500 | Cabinet B | 29.1 | 71 |
| 1 000 | Cabinet C | 61.3 | 145 |
| 1 440 | Cabinet C | 63.4 | 189 |

347 V

| Watts (W) | Cabinet | without battery(s) (lbs) | with battery(s) (lbs) |
|-----------|-----------|--------------------------|-----------------------|
| 320 | Cabinet B | 41.2 | 65 |
| 500 | Cabinet B | 42.1 | 84 |
| 1 000 | Cabinet C | 98.3 | 182 |
| 1 440 | Cabinet C | 100.4 | 226 |

Data is based upon tests performed in a controlled environment. Actual performance can vary depending on operating conditions. All products are subject to change or may be discontinued any time without notice.

DIMENSIONS

Cabinet B

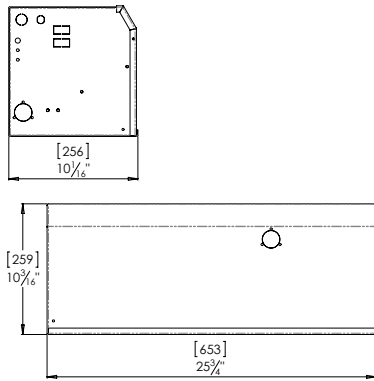

Cabinet C

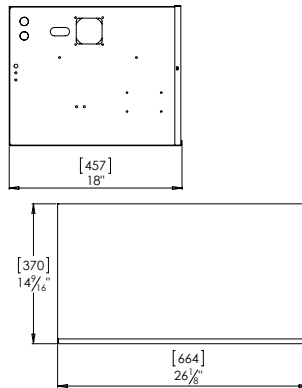

EXPLODED VIEW

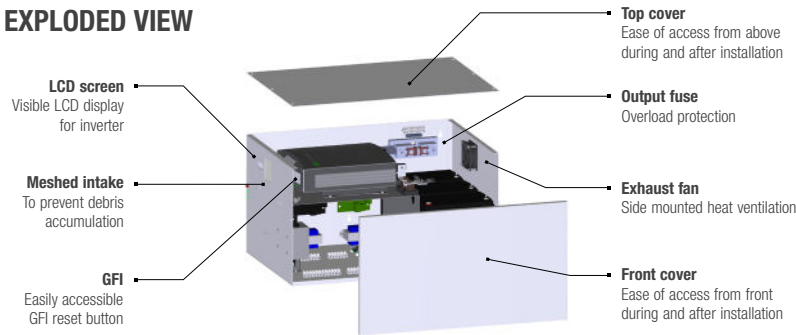

SHELF001

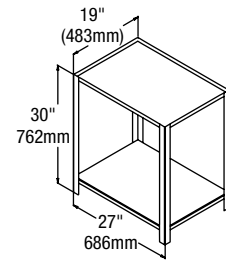

Data is based upon tests performed in a controlled environment. Actual performance can vary depending on operating conditions. All products are subject to change or may be discontinued any time without notice.