

Series Spec Sheet

SLM-2L

MINIATURE LED PLASTIC BATTERY UNIT

120/277VAC

The SLM-2L series of battery units is designed using a flame retardant plastic enclosure and utilizes a quick connector for easy installation. The SLM-2L provides emergency light thanks to two fully adjustable glare-free shape light heads.

FEATURES AND SPECIFICATIONS

• Electrical Circuitry

- LED ultra-bright light source
- 120/277 VAC Input, field selectable
- Power consumption:
120V/0.06A/0.4W or 277V/0.07A/0.5W
- 3.6V maintenance free NI-CAD battery
- 90 minutes emergency lighting duration
- 3.6V 1W long life LED light source, 6000K

• Mechanical

- Injection molded thermoplastic housing
- Suitable for damp location
- Fully adjustable lamp holder location
- White color is standard
- Solid state transfer and battery charger
- Wall and ceiling mount installations

• Approvals

- Meets or exceeds CSA C22.2 #141-10



OVERVIEW

Light source	LED
Input voltage	120/277 VAC
Power consumption	120 V/0.06 A/0.4 W or 277 V/0.07 A/0.5 W

For complete warranty details, please see our terms and conditions on our website.



ORDERING GUIDE

SLM
Series
SLM-2L

DIMENSIONS

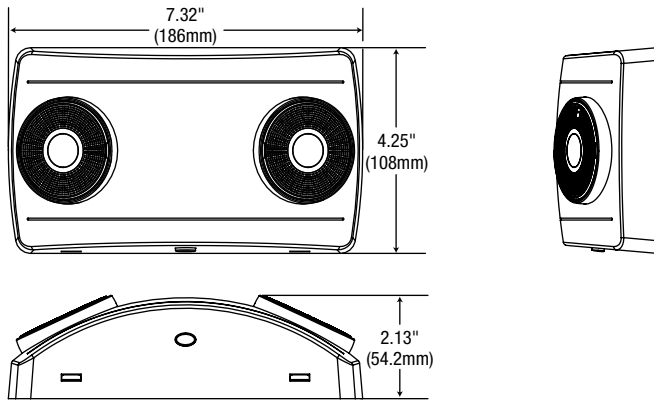

SPACING GUIDE

Mounting height	Path Width	Spacing
7.5 ft	3 ft	28 ft
7.5 ft	6 ft	24 ft
10 ft	3 ft	23 ft
10 ft	6 ft	20 ft

Data is based upon tests performed in a controlled environment. Actual performance can vary depending on operating conditions. All products are subject to change or may be discontinued any time without notice.