

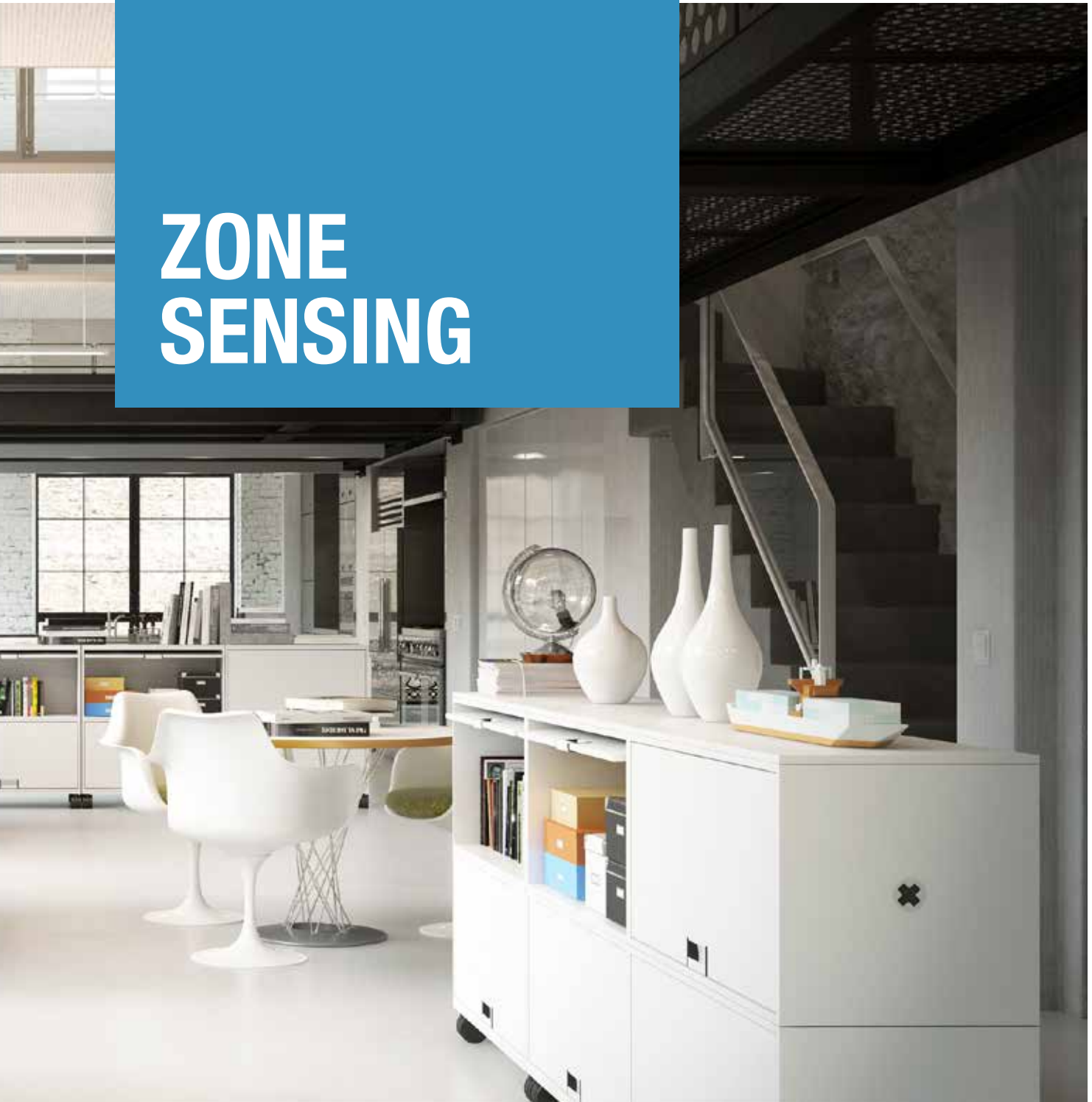

ZONE SENSING









WHY WE NEED ZONE SENSING

When a monitored lighting circuit loses AC power, a closed relay opens, which triggers emergency lighting in the affected lighting circuit area to be activated while the other emergency lighting in the same building that has no loss of power to the monitored lighting circuits, remains off.



ADVANTAGES OF ZONE SENSING

- Preserves the life of the sealed lead batteries. (AT feature should be used in conjunction)
- Unaffected areas would have regular AC power still being delivered to those unaffected areas, while on delivering emergency lighting power to the area required (ex. 1 floor of an apartment building vs the whole building)

REQUIRED

Initially specified for the Armed Forces, was soon adopted province wide and put into the Building Inspector's check list for all new construction to ensure the lighting circuits in paths of egress are monitored.

ZONE SENSING TYPES

EXTERNAL ZONE SENSING

External zone sensing panel limitless amount of zones (lighting circuits), any voltages to be monitored.

Usually installed near lighting panel, where lighting circuits will flow through separate wiring and pipe to go to battery unit(s).

AC OUTPUT OR DC OUTPUT

Battery as well as zone sensing control all in 1 cabinet. Maximum 6 monitored circuits and 6 outputs per cabinet.

AC output provides power towards the battery. DC output provides power towards the remote & signs.





INTERCONNECTION BETWEEN ELECTRICAL PANEL, ZONE SENSING & BATTERY UNIT

EXAMPLES OF SPECIAL APPLICATIONS

- *Emergency Egress with Zone Sensing Devices Centrally Located*
- *Central location assists with testing function – Zone Relays have a Integral Test Button*

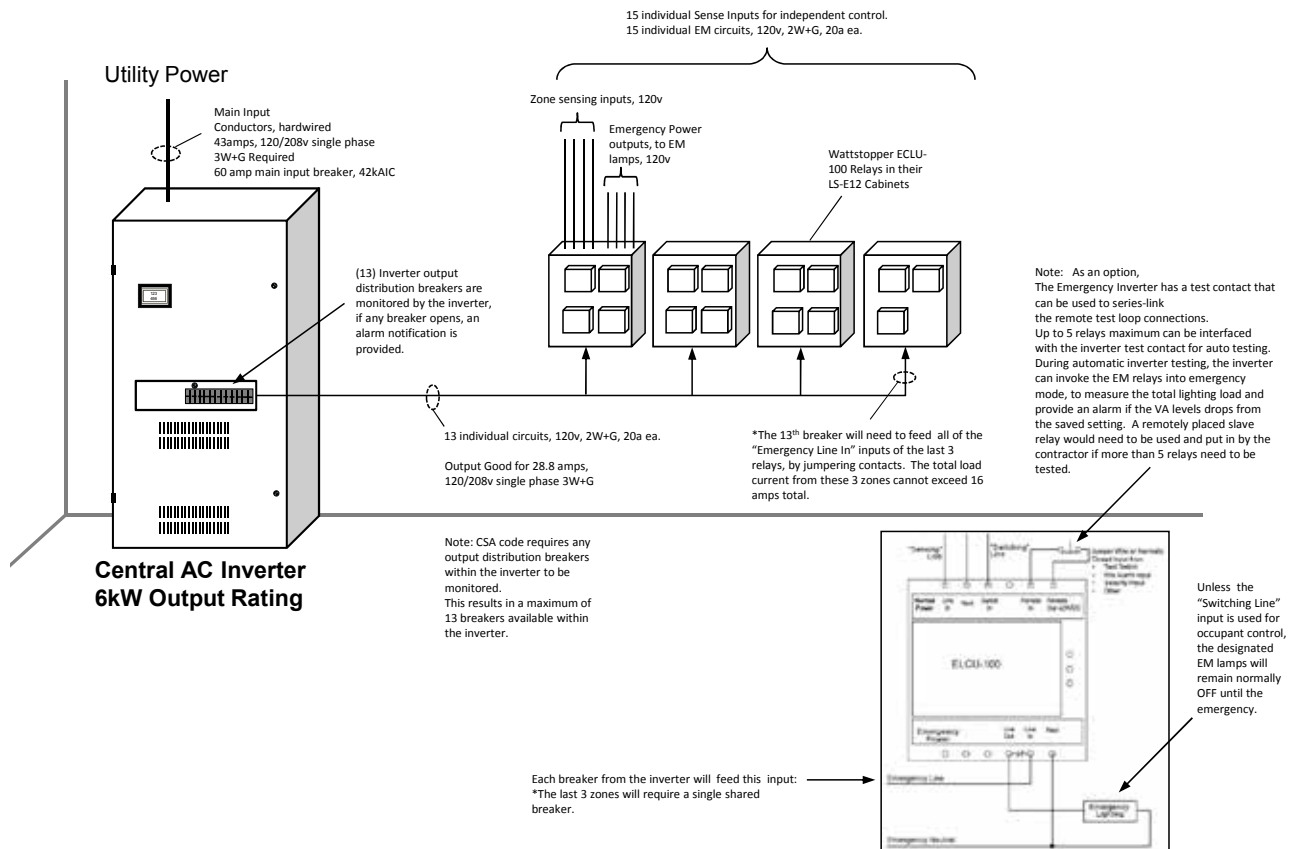

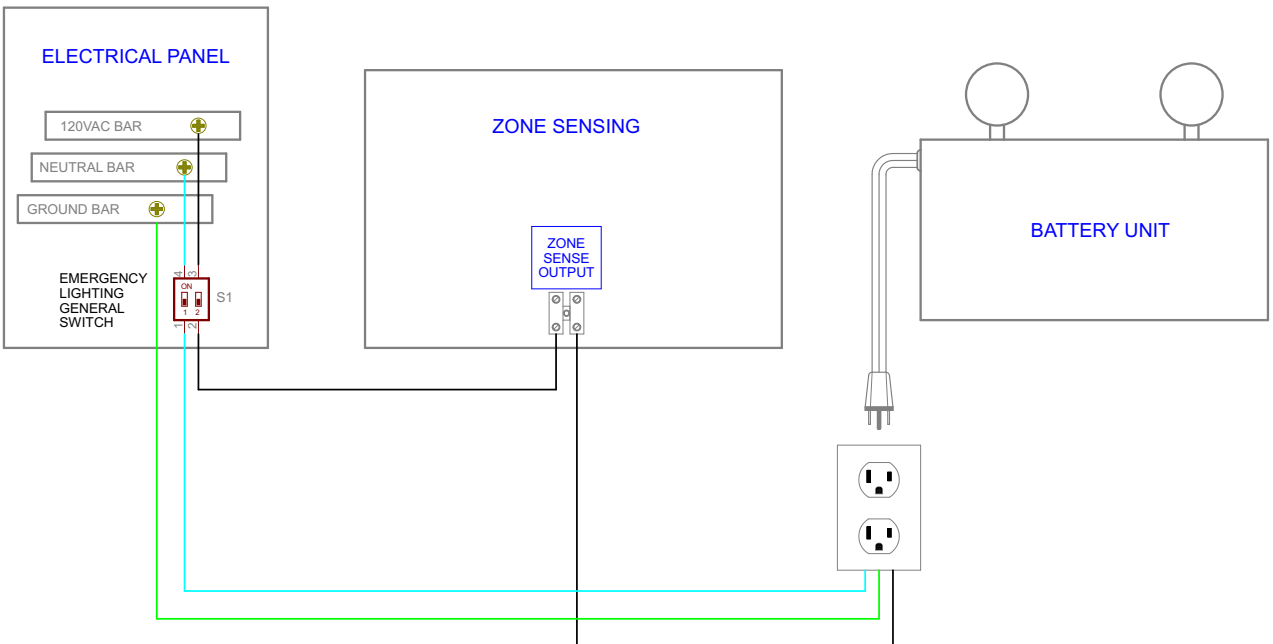

SLZC2

ZONE SENSING CONTROL PANEL

Complies to the Winnipeg by-law No. 77/2015

Complies to the Alberta Electrical Safety Bulletin 10-2017
CEC-046

The SLZC2 series is the latest generation of zone sensing control units. It's designed to monitor electrical circuits at various voltages (120VAC, 277VAC, and 347VAC). The SLZC2 will automatically trigger emergency lighting operation upon loss of AC current. With the SLZC2, emergency lighting will come on if a zone monitored loses power (triggering emergency lighting specific to that zone). The unit comes standard with zone test switch and zone pilot lights, for easy monitoring and testing. It is also compatible with Stanpro autotest battery units. This new design is clear and simple to install.

FEATURES AND SPECIFICATIONS

• Circuitry

- Up to 6 circuits monitored (inputs) per cabinet
- AC (formally external zone sensing) or DC (formally internal zone sensing)
- Up to 6 outputs
- 120/277/347 VAC input
- 120/277/347 VAC output
- Zone pilot lights are standard
- Zone test switch are standard
- Compatible with Stanpro's automatic-testing, self-diagnostic boards
- Clearly identified terminal blocks with high gauge caliber, for easy wiring

• Mechanical

- Rugged steel cabinet with ultraguard rust-coating
- 24 knockouts for easy installation
- Pivoting door
- Keyhole mounting slots stamped into back of cabinet
- Built and assembled in Canada
- Grey powder coat finish is standard

• Compliances

- CSA Certified to C22.2 #141-15
- Meets requirements of ICES-005



DIMENSION

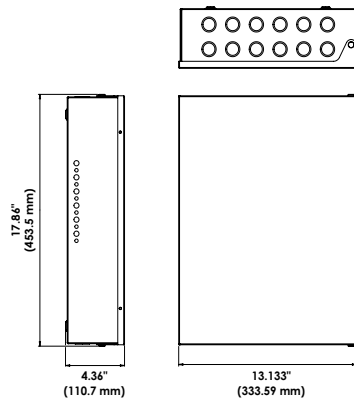

canadian
made



ICES
005



ORDERING GUIDE

Series	# of monitored circuits (?c)	Relay Control Output (?O)	Current	Color	Program ¹
SLZC2	_C - (Between 1 and 6)	_O - (Between 1 and 6 - no more than #C)	AC DC	GY - Grey (Standard)	To be completed by a Stanpro representative

¹ Complete the quiz and submit it to your customer service representative for proper configuration



AC OUTPUT WIRING DIAGRAM

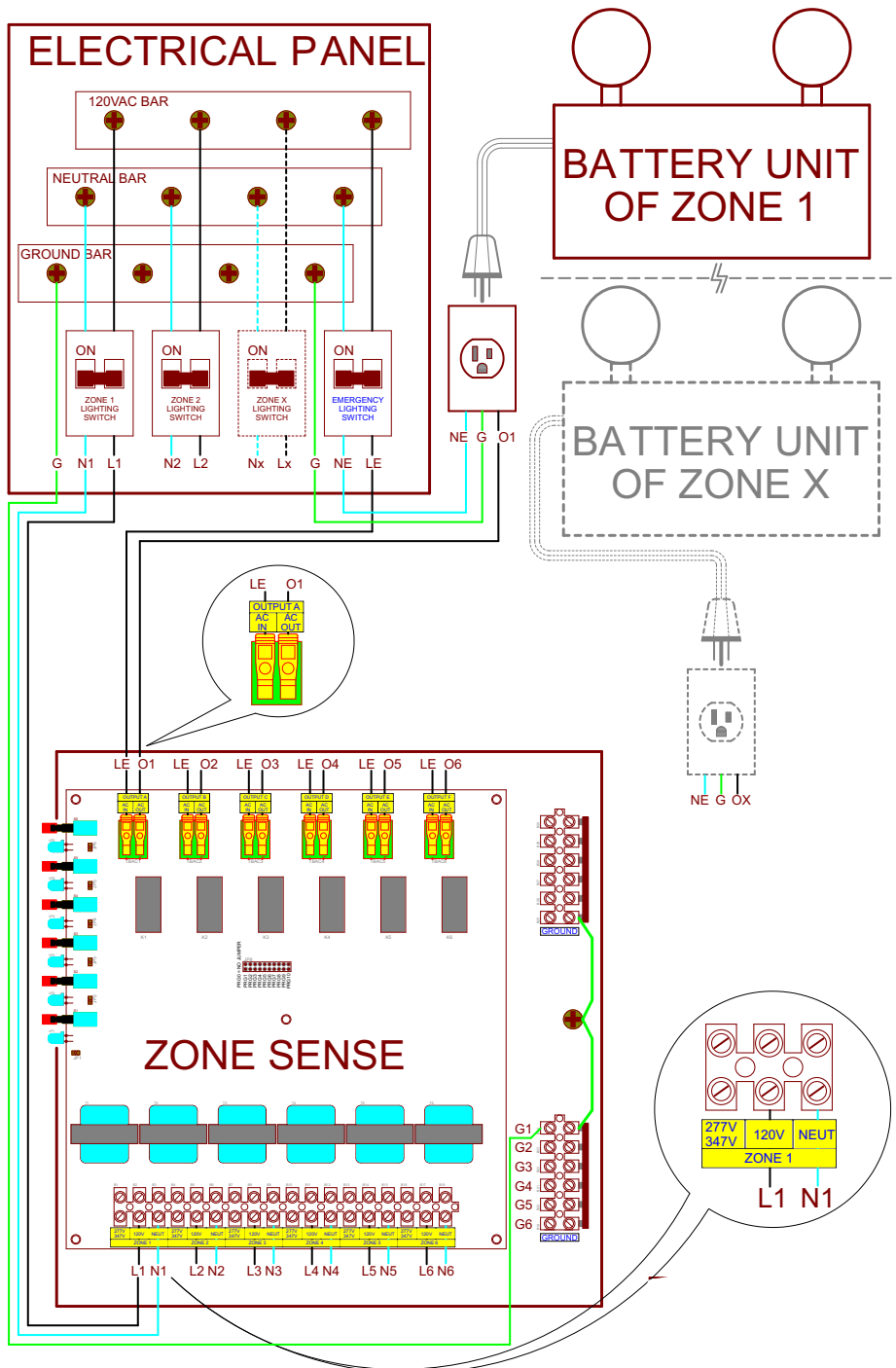

DC OUTPUT WIRING DIAGRAM

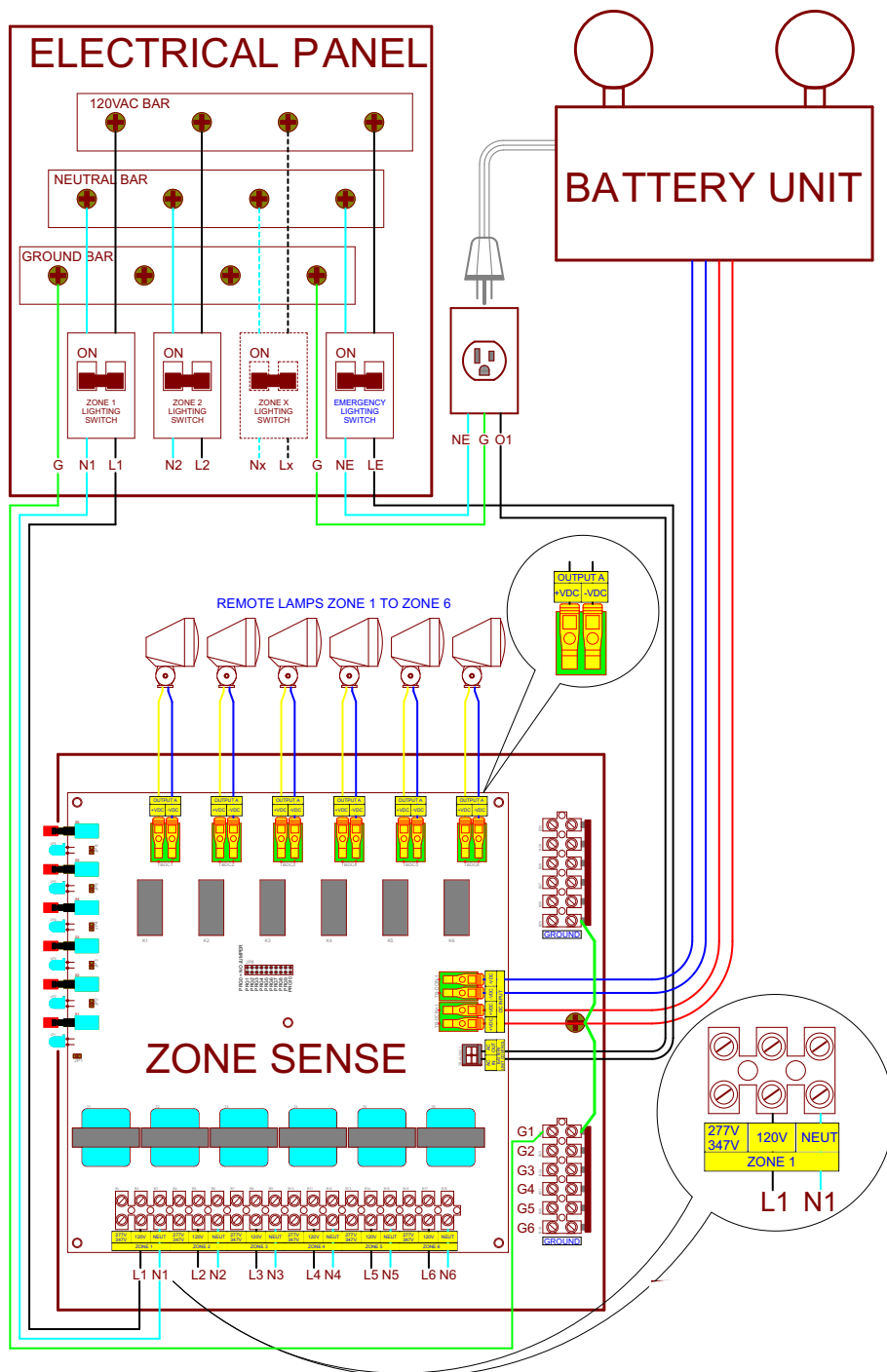

DIFFERENCE BETWEEN TRADITIONAL SETUP & ZONE SENSING

TRADITIONAL







TRADITIONAL



When lighting circuits are individually monitored, only specific emergency lighting will come on.

When lighting circuits are parallel monitored, all the emergency will come on in the lighting circuits that are being monitored (as in the case of having regular emergency lighting).

-  LIGHTS ARE ON
-  ZONE FAILS
-  EMERGENCY GOES ON
-  NOTHING HAPPENS

ZONE SENSING (INDIVIDUAL)



ZONE SENSING (PARALLEL)



GETTING STARTED

ZONE SENSING QUIZ

How many circuits are you monitoring? _____

How many outputs are required? (Each output corresponds to a single battery unit)? _____

Will the output of the power be AC (towards the battery) or DC (towards the remote & signs)? _____

Draw lines to identify what are you zone grouping together for each battery, starting with the latest group

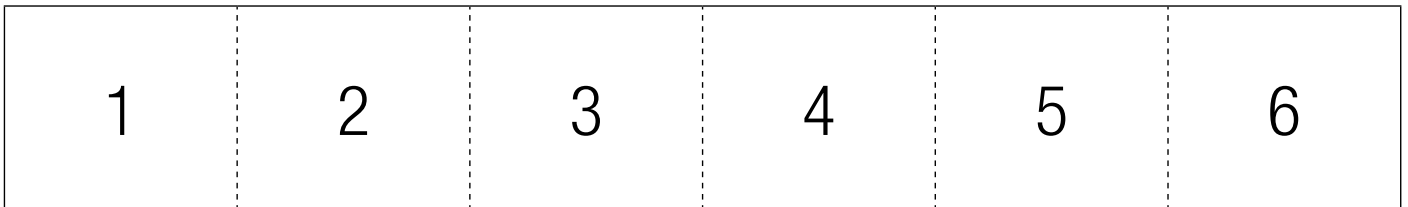

I.E:
5 circuits, 2 outputs.
4 circuits for the 1st output.
1 circuit for the 2nd output

4 circuits, 3 outputs.
2 circuits for the 1st output,
1 circuit for the 2nd output,
and 1 circuit for the 3rd output

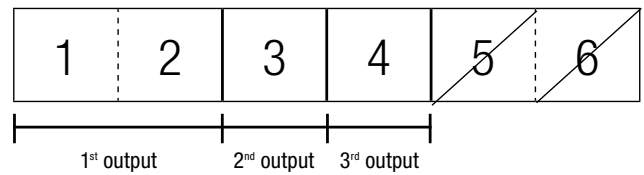
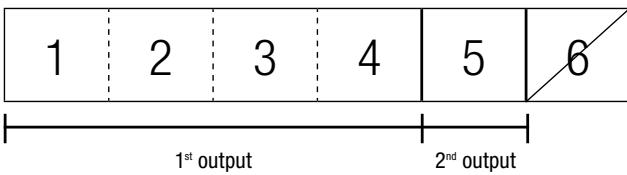





Printed in Canada.
© 2021 STANDARD Products Inc. All Rights Reserved.

Data is based upon tests performed in a controlled environment.
Actual performance can vary depending on operating conditions.
All products are subject to change or may be discontinued any time
without notice.

For the latest version, please refer to our website.
www.standardpro.com



STANPRO



STANPRO