



NOAH

EMERGENCY LIGHTING
WET LOCATION FAMILY







FEATURES

- The molded gasket completely seals the housing from the elements
- Reinforced polycarbonate construction - will not corrode or rust from water exposure
- CSA Sanitation certified to NSF 2 for food processing plants
- Available with LED or Quartz Halogen lamps
- Cold Weather option at -40°C to +40°C
- Offered in black or white
- Suitable for indoor/outdoor installation



RMRN

“NOAH”
RUNNING MAN
SIGN



- LED ultra bright light source
- High-performance Ni-Cd battery
- Auto test feature comes standard

66
wet
location

PRMRM

“NOAH”
RUNNING MAN
COMBO



- 120/277/347VAC Input
- 36W, 50W or 72W wattage capacity
- Temperature compensated charger
- Diagnostic/pilot LED
- Adjustable lamps

66
wet
location

SWN

“NOAH”
REMOTE



- 6VDC, 12DC or 24VDC
- Adjustable lamps

66
wet
location

SLBN

“NOAH”
BATTERY UNIT



- Fully automatic, current limited, trickle charger
- Magnetic test switch
- Auto test feature comes standard
- Adjustable lamps

66
wet
location

RMRN

“NOAH”

WET LOCATION ANTI VANDAL RUNNING MAN

120/277/347 VAC Input

The RMRN series of wet location anti vandal running man is designed to operate in extreme environments. The unit, designed using a polycarbonate housing, maintains its sealed interior with a continuous integral gasket. As well, LED pilot light and test switch are sealed type. Available in AC/DC and internally self-powered versions.

FEATURES AND SPECIFICATIONS

- **Electrical – AC/DC**
 - LED ultra bright light source
 - 120/277/347 VAC 60 Hz Input, field selectable
 - 2 W power consumption single or double face
 - 6 V, 12 V and 24 V universal DC
 - **6 VDC = 0.8 W, 12 VDC = 0.9 W, 24 VDC = 1.2 W**
- **Electrical – self-powered**
 - LED ultra bright light source
 - 120/277/347 VAC Input, field selectable
 - 3.34 W power consumption single or double face
 - High-performance, sealed Ni-Cad battery
 - 90 minutes emergency duration (standard)
120 minutes emergency duration is optional
 - Solid state transfer and battery charger
 - Auto test feature comes standard
- **Mechanical**
 - Reinforced polycarbonate construction
 - Stainless steel tamper proof screws and bits
 - One piece, molded and gasketed lens
 - Universal spider knockout pattern stamped into backplate for junction box mounting (backplate available with single face unit only)
 - Universal models include ceiling or end mount, field installable canopy kit
 - Comes standard at +10°C to +40°C
 - Cold weather at -20°C to +40°C is optional (available only with IB)
- **Approvals**
 - CSA Certified to C22.2 #141-15
 - CSA Certified to C860-11
 - CSA Certified type 2, 3, 3R, 4, 4X, 5,12 or 12K
 - CSA Certified to NSF 2
 - IP66
- **Compliance**
 - Meets requirements of ICES-005



OVERVIEW

Light source	LED
Input voltage (VAC)	120/277/347
Input power	2 W AC & AC/DC single or double face 3.34 W self-powered single or double face
DC voltage/power	6 VDC = 0.8 W 12 VDC = 0.9 W 24 VDC = 1.2 W

For complete warranty details, please see our terms and conditions on our website



LED
fixture



ICES
005



ORDERING GUIDE

Series	Nbr of faces	Mounting	Color	DC Volts (VDC)	Options
RMRN	1 - Single face 2 - Double face	Blank - Universal	BK - Black WH - White	UDC - Universal DC backup voltage from 6 to 24 IB - Self-powered for 90 minutes IB1 - Self-powered for 120 minutes	AT ¹ - Auto test standard CW ² - Cold Weather at -20°C to +40°C 0 - No indicators (double face only) ↓ ↑ ↗ ↘ ↙ ↘ D U UR DR DL UL

¹ Available only with IB & IB1.

² Available only with IB.

DIMENSIONS

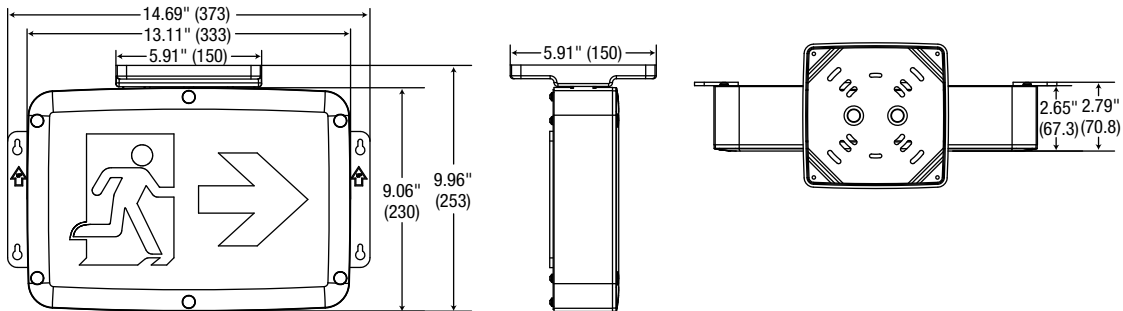

Comes standard (double face) with two pictogram legends.



For double face no arrow options, select "No indicators" on the options column.



Comes standard (single face) with three pictogram legends for direction selection.

PRMRN

“NOAH” WET LOCATION ANTI VANDAL RUNNING MAN COMBO

The PRMRN series of wet location combination running man exit signs is designed to operate in extreme environments. The PRMRN series is designed using a polycarbonate housing. The housing features integral wall mounting points and a molded gasket that completely seals the housing from the elements.

FEATURES AND SPECIFICATIONS

• Electrical and circuitry

- LED ultra bright light source
- 120/277/347 VAC 60 Hz Input, field selectable
- 30 minutes minimum emergency power duration (depending on selected lamp type)
- Temperature compensated charger
- Diagnostic/pilot LED
- Complete battery recharge in 24 hours

• Mechanical

- One piece, molded and gasketed lens
- Stainless steel tamper proof screws and bits
- Universal spider knockout pattern stamped into backplate for junction box mounting
- Universal models include ceiling or end mount, field installable canopy kit
- Black or white finish
- Universal mounting

• Approvals

- CSA Certified to C22.2 #141-15
- CSA Certified to C860-11
- CSA Certified type 2, 3, 3R, 4, 4X, 5,12 or 12K
- CSA Certified to NSF 2

• Compliance

- Meets requirements of ICES-005

OVERVIEW

Light source	LED
Input voltage (VAC)	120/277/347
CW1 input voltage (VAC)	120/277, 347
CW1 input power (W)	30
DC voltage (VDC)	6, 12

For complete warranty details, please see our terms and conditions on our website.



ICES
005



ORDERING GUIDE

Series	Volts (V)	Watts (W)	Number of face	Housing color	Heads	Lamp selection	Mandatory options	Options
PRMRN	6 - 6	036 - 36 W Ni-Cd 050 - 50 W lead acid 072 - 72 W lead acid	1 - Single face 2 - Double face	BK - Black WH - White	2 - 2 heads	See lamp selection chart	AT - Autotest	Blank - Standard +10°C to +25°C CW1 ¹ - Cold Weather at -40°C to +40°C 0 - No indicators (double face only) ↓ ↑ ↗ ↘ ↙ ↘ D U UR DR DL UL
	1 - 12	036 - 36 W Ni-Cd	1 - Single face 2 - Double face					

¹ Available only with 36 W for 120/277/347 VAC.

MODEL RATINGS

Model	Volts (V)	Wattage capacities (W)			
		30 min.	60 min.	90 min.	120 min.
PRMRN6036	6	36	18	12	9
PRMRN6050	6	50	25	16.5	12.5
PRMRN6072	6	72	36	24	18
PRMRN1036	12	36	18	12	9

LAMP SELECTION

MR16 • Small head c/w MR16 or LED lamp	6 V	12 V
LED	4LR, 5LA	4LR, 5LA, 6LA, 7LA
Quartz halogen	10Q	12Q

SPACING GUIDE

Mounting height	Spacing center to center (ft)			
	4LR	5LA	6LA	7LA
8 ft	76	81	94	108
10 ft	79	79	93	106
15 ft	66	62	82	96
20 ft	53	49	73	87

DIMENSIONS

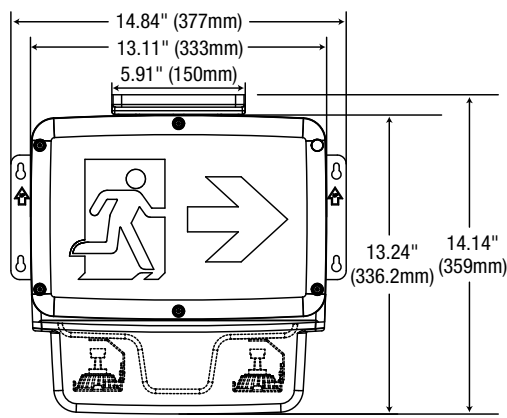

CONFIGURATIONS



Comes standard (single face) with three pictogram legends for direction selection.



Comes standard (double face) with two pictogram legends.



For double face no arrow options, select "No indicators" on the options column.

SWN

“NOAH” WET LOCATION ANTI VANDAL REMOTE

Single or double

6V, 12V & 24V lamps in LED & Quartz

The SWN series of wet location anti vandal remotes is designed to perform in extreme environments. The single or double lamp assemblies are completely protected from the elements within a fully gasketed polycarbonate housing. Available in 6 V, 12 V or 24 V models, utilizing quartz halogen or LED (bi-pin based) lamps.

FEATURES AND SPECIFICATIONS

- **Electrical and circuitry**
 - 6 VDC, 12 VDC or 24 VDC
 - Quartz halogen lamps - bi-pin based
 - LED lamps - bi-pin based
- **Mechanical**
 - Polycarbonate enclosure is fully gasketed around lens and canopy to prevent water infiltration
 - Stainless steel tamper proof screws and bits
 - Wet location
 - Lamps are fully adjustable
 - Fully gasketed housing
 - Available in white and black
 - Universal spider knockout pattern stamped into backplate for junction box mounting
- **Ambient Temperature**
 - -35°C to +40°C
- **Approvals**
 - CSA Certified to C22.2 #141-15
 - CSA Certified type 2, 3, 3R, 4, 4X, 5, 12 or 12K
 - CSA Certified to NSF 2
 - IP66
- **Compliance**
 - Meets requirements of ICES-005

OVERVIEW

Light source	LED or Quartz halogen
Input voltage (VDC)	6, 12, 24

For complete warranty details, please see our terms and conditions on our website.



ORDERING GUIDE - LED

Series	Nbr of heads	Volts (VDC operational)	Watts (W)	Lamp type	Color
SWN	1 - Single head	06-24V - 6 to 24	4W - 4	LR - LED	BK - Black WH - White
			5W - 5	LA - LED	
	2 - Double head	12-24V - 12 to 24	6W - 6	LA - LED	
			7W - 7		

ORDERING GUIDE - INCANDESCENT

Series	Nbr of heads	Volts (VDC)	Lamp type	Color
SWN	1 - Single head	06 - 6	See lamp selection chart	BK - Black WH - White
	2 - Double head	12 - 12		
		24 - 24		

INCANDESCENT LAMP SELECTION

	6 V	12 V	24 V
Quartz halogen	10WQ	12WQ	12WQ

DIMENSIONS

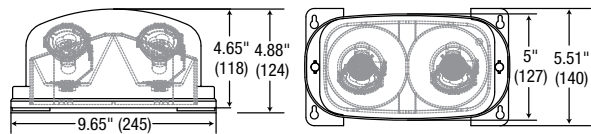
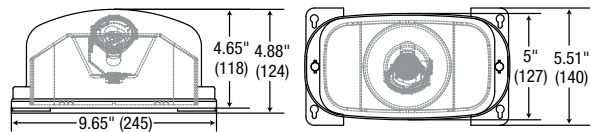

SPACING GUIDE

Mounting height	Spacing center to center (ft)			
	4WLR	5WLA	6WLA	7WLA
8 ft	76	81	94	108
10 ft	79	79	93	106
15 ft	66	62	82	96
20 ft	53	49	73	87

SLBN

“NOAH” WET LOCATION BATTERY UNIT

6 V or 12 V Models

36 W, 50 W, 72 W, 100 W or 130 W

The SLBN series of battery units is designed to operate in the most extreme environments. The unit, designed using a polycarbonate housing, maintains its sealed interior with a continuous integral gasket. The SLBN series is available in 6 VDC and 12 VDC versions in 36 W, 50 W, 72 W, 100 W or 130 W wattage capacity for a minimum of 30 minutes in emergency mode. Auto test feature is standard.

FEATURES AND SPECIFICATIONS

• Electrical and circuitry

- 120/277/347 VAC 60 Hz Input, field selectable
- High efficiency, rapid recovery, precision control charging system
- Magnetic test switch
- Diagnostic/pilot LED
- Fully automatic, current limited charger
- Temperature compensated charger
- Complete battery recharge in 24 hours
- Standard automatic-testing, self-diagnostic charger board

• Mechanical

- Universal spider knockout pattern stamped into backplate for junction box mounting
- Fully gasketed reinforced polycarbonate housing
 - will not corrode or rust from water exposure
- Stainless steel tamper proof screws and bits
- Black or white finish

• Approvals

- CSA Certified to C22.2 #141-15
- CSA Certified type 2, 3, 3R, 4, 4X, 5, 12 or 12K
- CSA Certified to NSF 2

• Compliance

- Meets requirements of ICES-005



OVERVIEW

Input voltage (VAC)	120/277/347
CW1 input voltage (VAC)	120/277/347
CW1 input power (W)	30
Output voltage (VDC)	6, 12
Output power (W)	36 - 130

For complete warranty details, please see our terms and conditions on our website



ORDERING GUIDE

Series	Volts (V)	Watts (W)	Lamp selection	Housing color	Mandatory options	Options
SLBN	6 - 6 1 - 12	036 - 36, Ni-Cd 050 - 50, lead acid 072 - 72, lead acid 100 - 100, lead acid 130 - 130, lead acid	See lamp selection chart	BK - Black WH - White	AT - Autotest	Blank - Standard +10°C to +25°C CW1 ¹ - Cold Weather at -40°C to +40°C

¹ Available only with 6 V, 36 W.

MODEL RATINGS

Model	Volts (V)	Wattage capacities (W)			
		30 min.	60 min.	90 min.	120 min.
SLBN6036	6	36	18	12	9
SLBN6050		50	25	16.5	12.5
SLBN6072		72	36	24	18
SLBN6100		100	50	33	25
SLBN6130		130	65	43	33
SLBN1036	12	36	18	12	9
SLBN1050		50	25	16.5	12.5
SLBN1072		72	36	24	18
SLBN1100		100	50	33	25
SLBN1130		130	65	43	33

LAMP SELECTION

MR16 • Small head c/w MR16 or LED lamp	6 V	12 V
LED	4LR, 5LA	4LR, 5LA, 6LA, 7LA
Quartz halogen	10Q	10Q, 12Q

DIMENSIONS

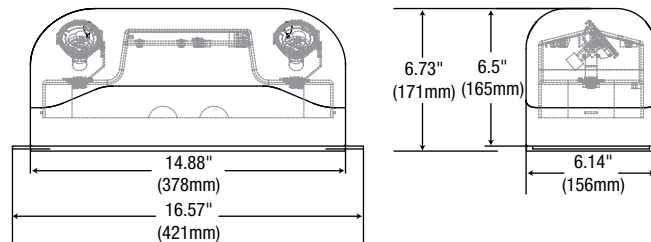

SPACING GUIDE

Mounting height	Spacing center to center (ft)			
	4LR	5LA	6LA	7LA
8 ft	76	81	94	108
10 ft	79	79	93	106
15 ft	66	62	82	96
20 ft	53	49	73	87



Printed in Canada.
© 2021 STANDARD Products Inc. All Rights Reserved.

Data is based upon tests performed in a controlled environment.
Actual performance can vary depending on operating conditions.
All products are subject to change or may be discontinued any time
without notice.

For the latest version, please refer to our website.
www.standardpro.com



STANPRO



standardpro.com

STANPRO